

# Toughbay™ Pro Range

Installation instructions for LED Highbay

**JCC** | a **LEVITON** company

## Warning & cautions

- It is recommended that luminaires are installed by a qualified electrician to ensure the installation complies with the local current wiring regulations.
- Any broken or damaged parts should be replaced as soon as possible. JCC will not accept responsibility for claims arising from sub-standard installations; which will void the warranty.
- This luminaire should be installed out of arms reach.
- The external flexible cable or cord of this luminaire cannot be replaced; if the cord is damaged the luminaire shall be destroyed.
- Terminal block not included. Installation may require advice from a qualified person.
- Caution. Risk of electric shock. ⚠
- The light source of this luminaire is not replaceable. This luminaire is suitable for indoor and outdoor use.
- It may be necessary to upgrade your MCBs to allow for increased inrush current.
- It is recommended that the ambient room temperature should not exceed 40°C.
- Ensure that you have the tools and accessories required to complete the installation correctly: Isolate the power before starting installation.
- Refer to Fig. 1 and Fig. 2 for input voltage for this range.
- Read instructions and check that you have all of the tools and accessories required to complete the installation correctly. Isolate power supply before starting the installation.

## INSTALLATION

ENGLISH

### Specifications

Colour Temp: 5700K(100/150/200W)(4000K 200W) Ra: 80

Wattage	Lumens	LpcW	Beam options
100W	14000	140	60°/90°/120°
150W	21000	140	60°/90°/120°
200W	28000	140	60°/90°/120°

Available finishes: Black only

### Standard version connection

100-277V~ 50/60Hz / Class I Ⓢ

Figure 1. Mains input

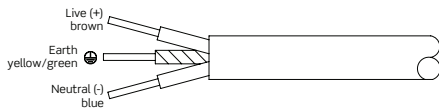

### Non-maintained Emergency version connection

220-240V~ 50/60Hz / Class I Ⓢ

Figure 2.

Wire preparation  
1.0-1.5mm □

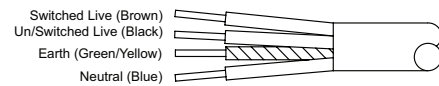
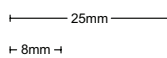

### 1-10V Dimming control input

Figure 3.

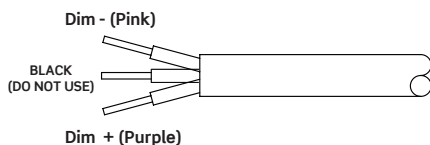

### Standard dimmable version installation procedure

- The luminaire comes with a fixed eye(s) for suspension as standard.
- For surface mounting please order correct bracket separately (JC040224). Fit the bracket to a flat surface ensuring that fixings are suitable to hold the weight of the luminaire. Fit the luminaire to the bracket using the bolts supplied with the bracket.
- Connect the mains input as shown in Fig.1, using a suitable connector to maintain the IP rating for the location.(not supplied). Please ensure that suitable cable for the application is used.
- This luminaire is 1-10V dimmable as standard, if you wish to dim this fitting ensure that you connect the 1-10V dimming control wires as shown in Fig.3 to a 1-10V dimming system only. If no dimming is required please leave the terminals isolated.

### Emergency dimmable version installation procedure

- The luminaire comes with a fixed eye(s) for suspension as standard.
- Connect the mains input as shown in Fig.2, using the connector (supplied). Please ensure that suitable 4-core cable for the application is used.  
To identify the correct terminals for mains input, unscrew/loosen the collar to expose the cables and match the connections to the corresponding colours in Fig.2
- Once the mains supply is connected and the fitting is installed, connect batteries. The LED charge indicator will illuminate showing the fitting is in charge mode and is working correctly. Allow 24hrs for the batteries to charge prior to testing in emergency mode.
- This luminaire is 1-10V dimmable as standard, if you wish to dim this fitting ensure that you connect the 1-10V dimming control wires as shown in Fig.3 to a 1-10V dimming system only. If no dimming is required please leave the terminals isolated.

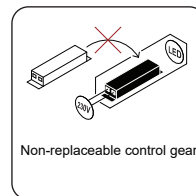

Non-replaceable control gear

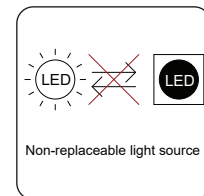

Non-replaceable light source

UK  
CA

CE

Ⓢ

RoHS  
Compliant

IP65

jcc.co.uk

## Important warranty information

This product is supported by a 2-year standard warranty which will extend to 5 years if registered within the first year of purchase. (5 year on batteries). Please register at [jcc.co.uk/warranty](http://jcc.co.uk/warranty) - Terms and conditions apply.

The installer will be asked to provide the following information, which is detailed on a label attached to the luminaire's chassis: Product Code/Date Code.

BS EN ISO9001 - 2015 - Registered Firm Certificate No. GB 1552  
JCC Lighting Products Ltd. Lux Park, Chichester Business Park, City Fields Way, Tangmere, Chichester, West Sussex, PO20 2FT  
Technical Support: +44(0)1243 838986 Customer Services: +44(0)1243 838999

V4\_APR\_2024\_RS

## POWER SELECTABLE

Select Wattage	
▲	60W
●	80W
▼	100W

Select Wattage	
▲	90W
●	120W
▼	150W

Select Wattage	
▲	100W
●	150W
▼	200W

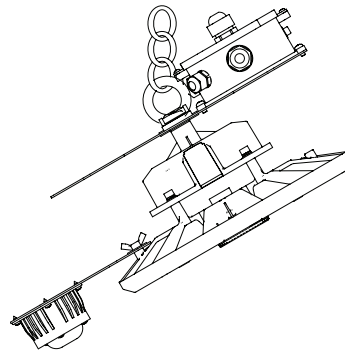
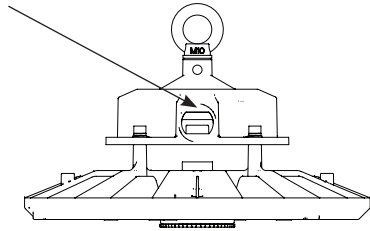

**X**

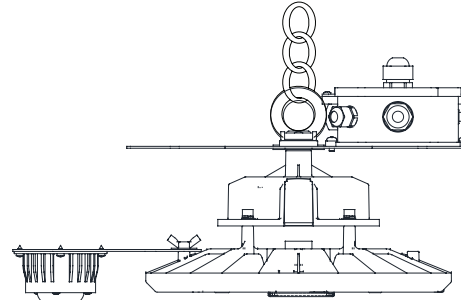

**✓**

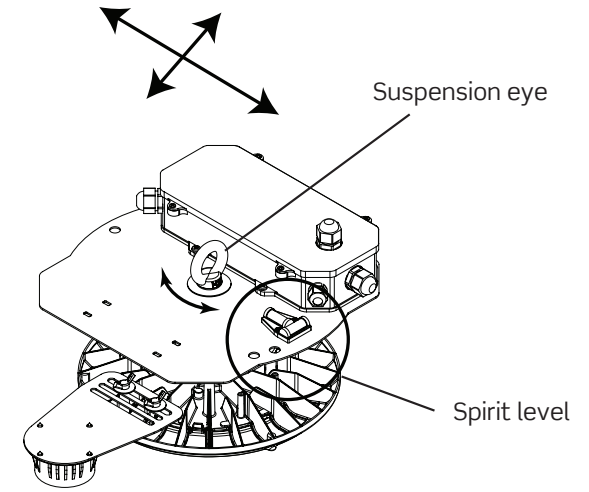

Suspension eye

Spirit level

## TOUGHBAY™ PRO HAS THE OPTION TO CHANGE THE POWER OUTPUT

1. ISOLATE POWER
2. REMOVE RUBBER COVER AND SELECT REQUIRED OUTPUT
3. REFIT RUBBER COVER TO MAINTAIN IP RATING
4. TURN ON POWER

NOTE DEFAULT IS SET TO HIGH OUTPUT

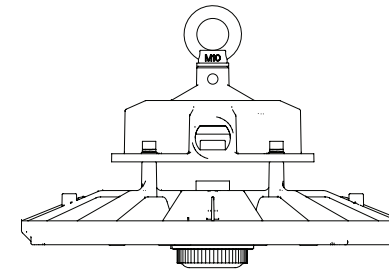
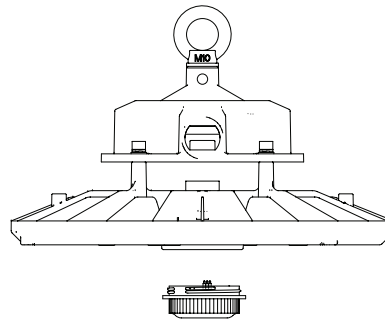
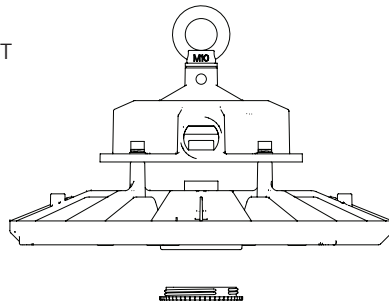

### Isolate power before installing sensor

1. Remove blanking cap in the centre of the lens by rotating anti-clockwise

2. Fit chosen sensor making sure not to cross the threads and rotate clockwise until hand tight -do not overtighten

Note: Both sensors are IP65 rated when installed correctly

LEV71950 - PIR dim Sensor

LEV71951 - MW Dim Sensor

\*Requires LEV71808 Remote control to operate sensors

100W

Profile & Dimensions

150W

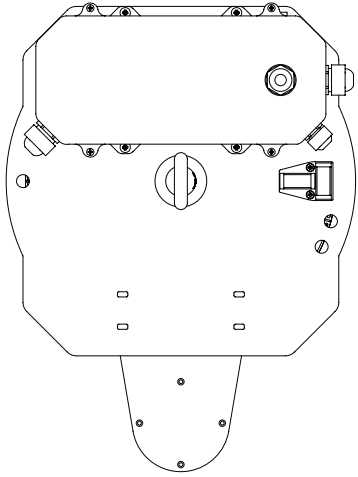

359.4

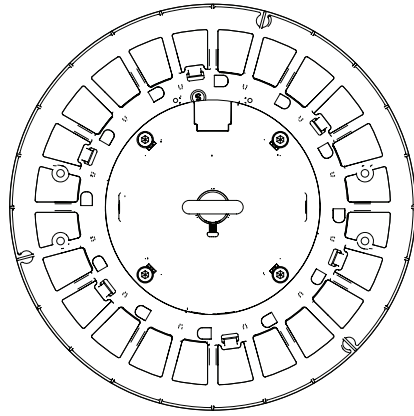

240.0

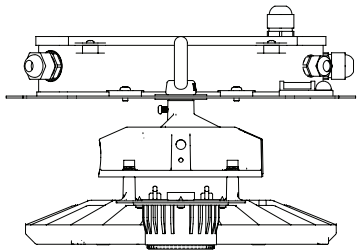

198.0

270.0

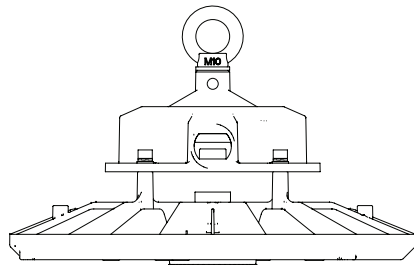

155.0

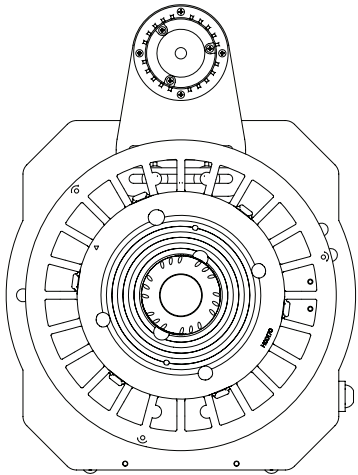

359.4

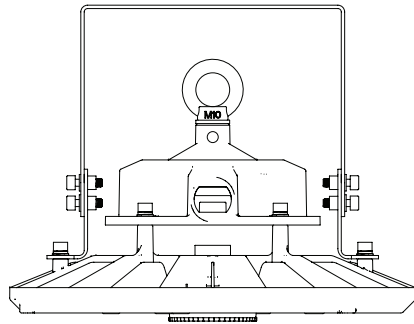

187.0

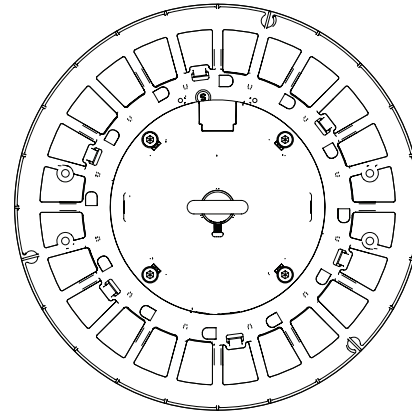

240.0

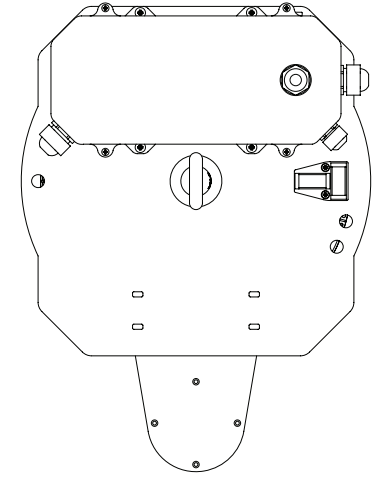

359.4

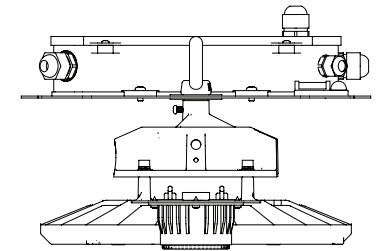

198.0

270.0

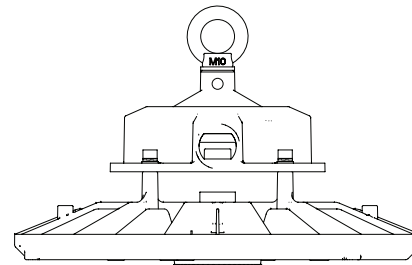

169.0

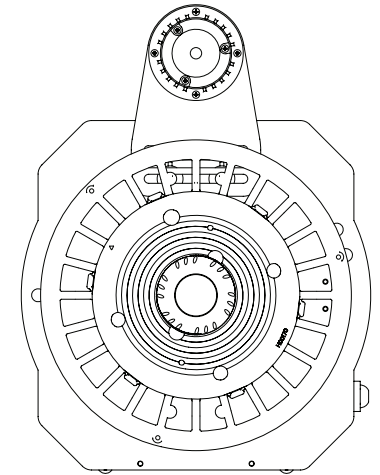

359.4

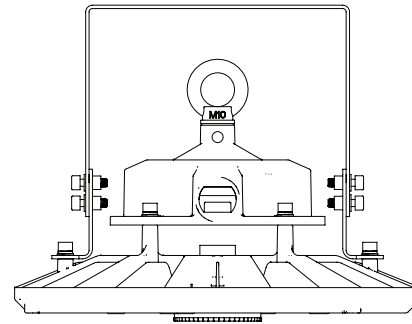

191.0

200W

# Profile & Dimensions

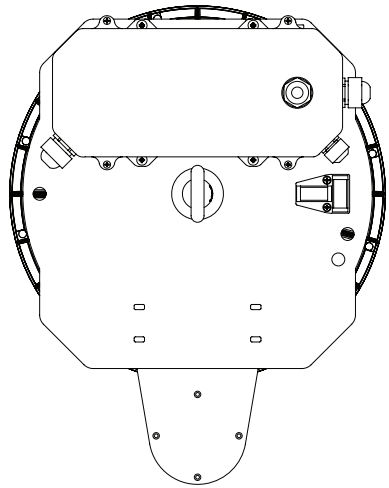

370.0

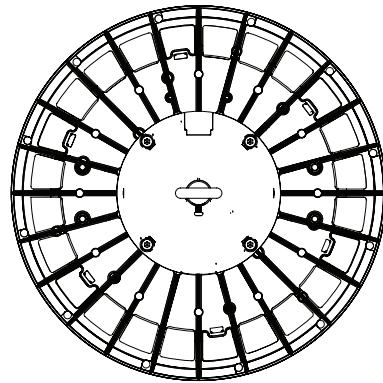

290.0

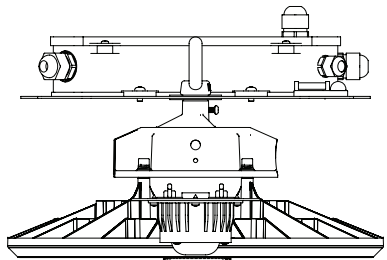

194.0

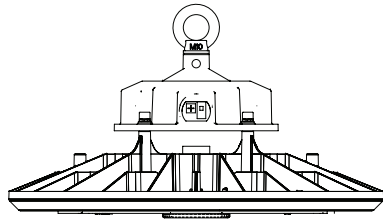

165.0

290.0

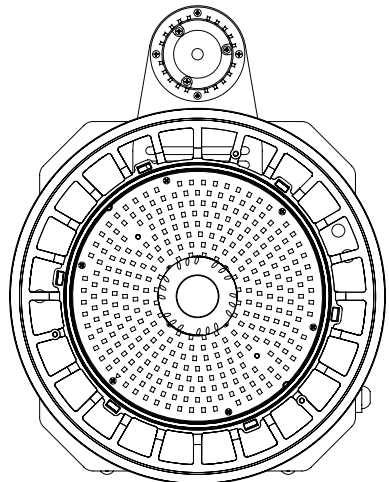

370.0

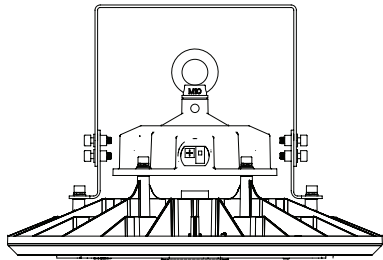

199.0

## SURFACE BRACKET

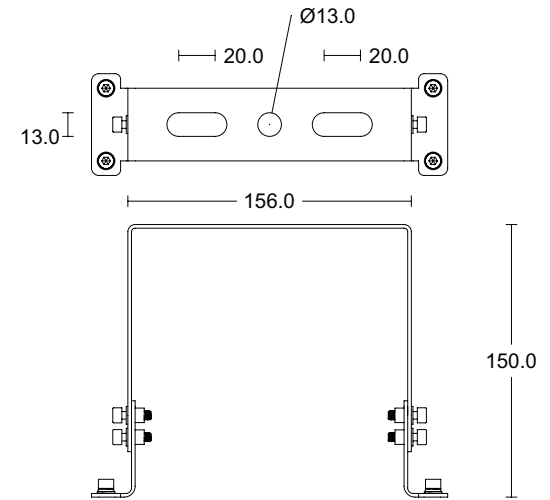

SURFACE MOUNT BRACKET- ALL WATTAGES  
(NOT SUITABLE FOR EMERGENCY VERSIONS)

## PIR DIM SENSOR

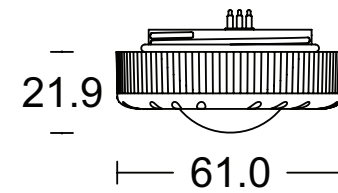

## MW DIM SENSOR

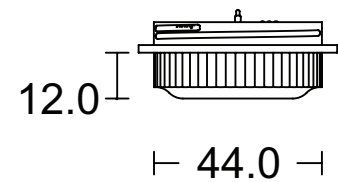

# Toughbay™ Pro Range

## Emergency range routine inspection and test

All tests must be undertaken at times of least risk and in accordance with EN 50172:2004 as indicated below:

Daily: Indicators of central power supply shall be visually inspected for correct operation.

Monthly: (in addition to the daily check) If automatic testing devices are used, the results of the short duration tests shall be recorded. Test shall be carried out as follows:

- a) Switch the luminaire over to emergency mode to operate from the batteries by simulating a failure of supply to the normal lighting for a period sufficient to ensure correct luminaire operation

NOTE: The period of simulation failure should be sufficient for the purpose of this clause whilst minimising damage to the system components e.g lamps. During this period, all luminaires and signs shall be checked to ensure that they are present, clean and functioning correctly. At the end of this test period, the supply to the normal lighting should be restored and any indicator lamp or device should be checked to ensure that it is showing that the normal supply has been restored

Annually: If automatic testing devices are used, the results of the short duration tests shall be recorded. For all other systems the monthly inspection shall be carried out and the following additional tests made:

- a) Each luminaire and internally illuminated sign shall be tested monthly as above but for its full duration in accordance with the manufacturer's information.
- b) The normal supply for the luminaire should be restored and any charge indicator lamp or device should be checked to ensure that it shows the normal supply has been restored.  
The charging arrangements should be checked for proper functioning.
- c) The date of the test and its results shall be recorded in the system logbook.

A copy of this report must accompany any fitting returned to the manufacturer for any reason.

## General Information

Our products are designed to comply with the requirements of UK law and the relevant industry national and international standards and should not be modified in any way. All emergency lighting systems should comply with the recommendations of BS5266-1: Code of Practice for the Emergency Lighting of Premises and be installed by competent engineers in accordance with the relevant wiring regulations. Before installing any type of Emergency Lighting always seek the advice and approval of the local Fire Prevention Officer (or equivalent authority).

## Maintenance

Failed or faulty light sources connected to this equipment should be replaced immediately. These units are designed especially for a long and trouble free life. Under normal conditions, will require no routine maintenance or service beyond the inspection and test regime of BS5266-1.

Both mains supply and battery protection fusing is incorporated internally. Should access to these or any other part of the circuitry be required this must be undertaken only by suitably qualified person. Special care must be taken when removing the cover to circuitry and battery. Only replacement components authorised by the company must be used. Disposal of replaced components should be in accordance with the component manufacturers instructions.

## Emergency Charge Indicator

Fault/Test/Status	Reason	Indicator Status
Battery charged	Normal operation	Solid green
Battery charging	Initial charge/top up	Green light flashes, 1 sec on/1 sec off
Auto test - 5 mins	30 day test	Green light flashes, 3 secs on/3 secs off
Auto test 180 mins	Duration test (Every 360 days)	Green light flashes, 3 secs on/1 sec off
Auto test 180mins - failure	Duration test Failure	Red light flashes, 0.5 sec on/0.5 sec off
Load failure	Open circuit/short circuit-LED failure (emergency mode)	Red light flashes, 2 secs on/2 secs off
Battery fault	Battery faulty/disconnected	Solid Red
DC mode	Battery operation(emergency mode)	No indicator light

Month	Test Type	First Year		Second Year		Third Year		Fourth Year		Fifth Year	
		Sign	Date	Sign	Date	Sign	Date	Sign	Date	Sign	Date
January	Functional										
February	Functional										
March	Functional										
April	Functional										
May	Functional										
June	Functional										
July	Functional										
August	Functional										
September	Functional										
October	Functional										
November	Functional										
December	3 hour										

BS EN ISO9001 - 2015 - Registered Firm Certificate No. GB 1552

JCC Lighting Products Ltd. Lux Park, Chichester Business Park, City Fields Way, Tangmere, Chichester, West Sussex, PO20 2FT

**Technical Support: +44(0)1243 838986 Customer Services: +44(0)1243 838999**